



**HOLDERS (300 SERIES THREADED) PREMIUM (EJECTOR)
WATER COOLED ELECTRODE HOLDERS**

FEATURES AND SPECIFICATIONS

Features and Benefits

- Long life CMW3 barrel.
- Ejector style water-cooled holders

Use With

- 18-750 series adapters

Mechanical

- Threaded for use with adapters

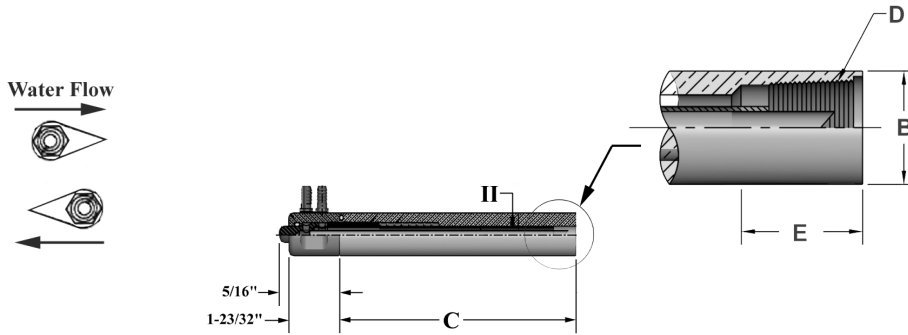

ORDERING INFORMATION AND DIMENSIONS

C BARREL LENGTH	D THREAD SIZE	B BARREL DIAMETER	PART NO. HOLDER ASSEMBLY	E ENGAGEMENT WITH STD. ELECTRODE	II SLIDING TUBE (REPLACEMENT PART)	USE WITH ADAPTERS
8	7/8-14	1	18-372	9/16	18-10047-8	18-7702
		1-1/4	18-373			18-7712
	1-14	1-1/4	18-375	3/4	18-10047-8	18-7852
		1-1/2	18-376			18-7862
						18-7864
						18-7872

HOLDERS