

HEAVY DUTY OFFSET HOLDERS

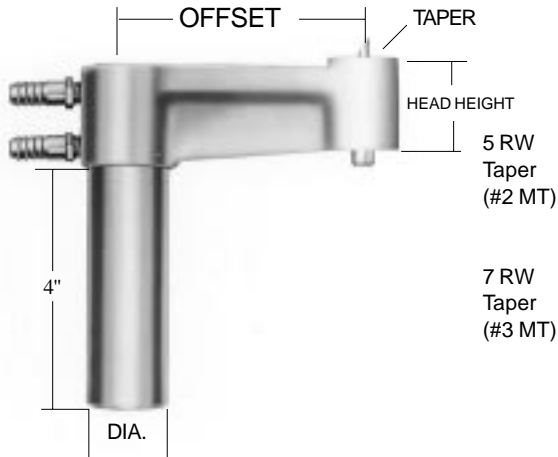

90 DEGREE HEAVY DUTY OFFSET HOLDERS EJECTOR TYPE

Part Number	Offset	Shank Diameter	Head Height
T-9021	2	1-1/4	1-7/8
T-9022		1-1/2	
T-9041	4	1-1/4	
T-9042		1-1/2	

T-9023	2	1-1/4	2-1/4
T-9024		1-1/2	
T-9043	4	1-1/4	
T-9044		1-1/2	

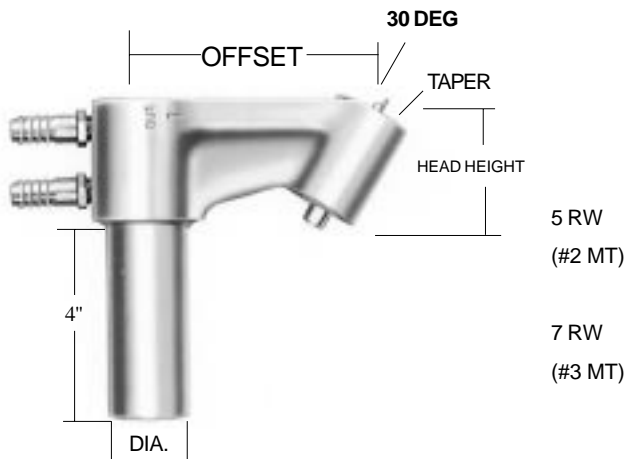

30 DEGREE HEAVY DUTY OFFSET HOLDERS EJECTOR TYPE

Part Number	Offset	Shank Diameter	Head Height
T-9341	4	1-1/4	1-7/8
T-9342		1-1/2	

T-9343	4	1-1/4	2-1/4
T-9344		1-1/2	

SPECIAL CAST AND COLD FORMED HOLDERS ARE AVAILABLE ON A MADE TO ORDER BASIS.

PLEASE CALL OR FAX WITH YOUR CUSTOM REQUIREMENTS