

ENTRON

RESISTANCE WELDING

BASICS

WELDING SEQUENCE

DEFINITIONS

MACHINE SET-UP

RULES FOR MAKING GOOD WELDS

ENTRON Controls, Inc.
465 East Randy Road
Carol Stream, Illinois 60188
(630) 682-9600
FAX# (630) 682-3374

RWMA
MEMBER

700081A
REVISED 11/98

INTRODUCTION TO RESISTANCE WELDING

What is Resistance Welding? Resistance welding is one of many methods of fastening two or more pieces of metal together. Some of these methods are listed below in order to illustrate how resistance welding differs from the others.

1. Bolting
2. Riveting
3. Soldering
4. Arc Welding
5. Resistance Welding

Bolting, riveting, soldering and arc welding all require some additional material to be added to the metal being fastened together. Additionally, bolting and riveting require holes to be made into the metal for the rivets or bolts to fit. Resistance welding requires neither additional material nor holes in the metal.

How is a resistance weld made? The two pieces of metal to be joined are squeezed together by the electrodes on the welding machine so they are in good electrical contact. Then electric current is passed through them, heating them until they begin to melt at the spot

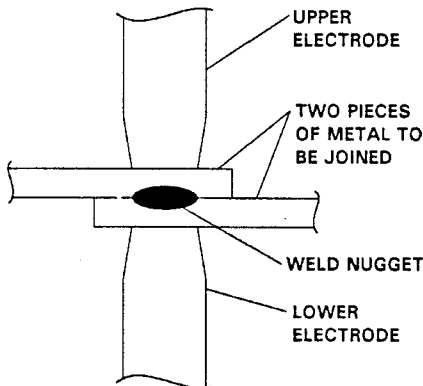

WHERE THE WELD IS MADE
Figure 1

where they are in contact. The molten metal from the two pieces flows together; then the current is turned off and the molten metal solidifies, forming a solid metallic connection between the two pieces. The term "Resistance Welding" comes from the fact that it is the electrical property of resistance of the metal being welded that causes heat to be generated when current flows through it.

What are the important factors in making a weld? Important to the proper formation of the molten area between the pieces of metal being welded is the magnitude of current, the length of time it flows, and the force squeezing the parts together. The optimum value of these parameters varies with the type of metal and its thickness. For commonly used low-carbon steel 1/16" thick, a typical value of current is 10,000 amps, for a time of 1/4 second, and 600 pounds electrode force. Resistance welding schedules are available through the American Welding Society, Resistance Welder Manufacturers Association, and from most welding machine manufacturers.

How is adequate current obtained? A current of 10,000 amps is not readily available from any standard electrical outlet. 15 amps is the maximum current available from common household and office outlets. Even in factories where large amounts of electrical energy is used, 200 amps is typical of the current available from electrical distribution circuits. Therefore, to get the 10,000 amps needed for resistance welding, some device must be used to step the current up from the relatively low level available from the power line.

The device generally used is a transformer. Transformers are usually thought of as stepping voltage up or down, but current can also be transformed in the same way. A transformer consists of two coils of wire, called the primary and secondary, wound around an iron core.

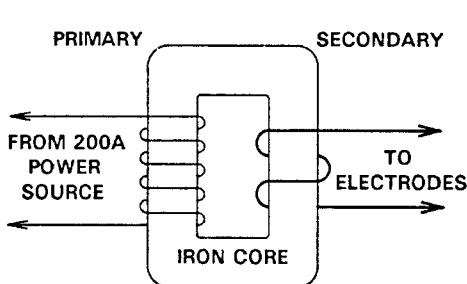

Power is transferred from primary to secondary via the magnetic properties of the iron. The factor by which the current or voltage is stepped up or down is roughly equal the ratio between the number of turns of wire in the coils

SIMPLIFIED DIAGRAM OF
A WELDING TRANSFORMER

Figure 2.

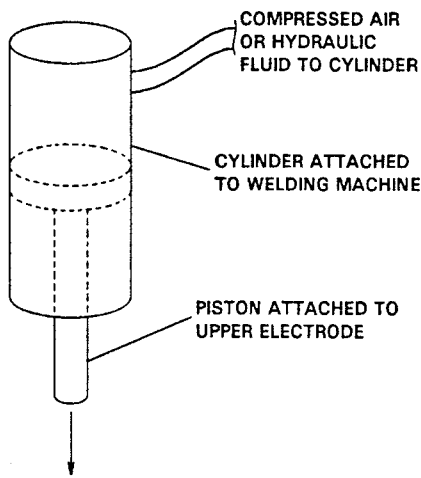

SIMPLIFIED DIAGRAM OF
THE WELD FORCE SYSTEM

Figure 3.

good electrical contact between the parts being welded, and to hold the parts steady until the molten metal forming the welded joint has time to solidify.

Depending on the size and type of welding machine, various methods of developing the electrode force are used, but the most common is to use compressed air in a cylinder and piston arrangement. The cylinder is rigidly attached to the welding machine

frame, and the moveable piston is connected to the upper electrode. Compressed air introduced into the cylinder develops a force on the piston which, in turn, pushes the electrode down against the metal being welded. The amount of force applied depends on the area of the piston and the pressure of the compressed air. In the preceding example where 600 pounds of electrode force was required, a five inch diameter piston would require an air pressure of 30 pounds per square inch.

What is a resistance welding control? It may be concluded from the preceding paragraphs that it is important to apply the welding current at the proper time during the operation of the welding machine. This is the function of the welding control; in fact, the purpose of a welding control is to coordinate the application of welding current with the mechanical motion of the welding machine. More specifically, it tells the electrodes when to close and when to open, and it tells the welding current when to start and when to stop. The welding control may be thought of as the "brains" and the machine as the "muscle" of the overall resistance welding system.

forming the primary and secondary windings of the transformer. In the preceding example, where 10,000 amps was required, a transformer could be made with 100 turns on the primary and 2 turns on the secondary; a "turns ratio" of 50. A 200 amp current in the primary would then be transformed into 200×50 , or 10,000 amps in the secondary, enough to do the welding job.

How is the time controlled? The length of time the welding current flows through the two pieces of metal to be welded is also important. Therefore, the device used to turn the current on and off is a critical part of the system. A relay or hand operated switch might be considered as a switching device, but either would be unsuitable because of the relatively slow speed of operation. In the preceding example, the current must be on for only 1/4 second. It is very difficult to turn a switch on and off again in 1/4 second, and even more difficult to do it consistently. Therefore, some electronic device with no moving parts should be used. Two such devices are available. The ignitron tube, which has been used for many years, is one, and the silicon controlled rectifier (SCR), a more recent development, is another. Both operate by virtue of the fact that a small electrical signal applied to the device allows it to turn on in a small fraction of a second and conduct a large amount of current. Removing the electrical signal allows the device to turn off again. Fast turn-on and turn-off are possible because there are no mechanical moving parts. Ignitron tubes operate on the principle of ionization of mercury vapor, while silicon controlled rectifiers operate on solid-state semi-conductor principles similar to transistors.

How is the electrode force obtained? The third critical factor in resistance welding is the force squeezing the metal parts together (Electrode Force). This force is necessary to assure

How is the welding control connected to the welding machine?

Since the welding control provides control of both welding current and machine motion, it must produce two control signals; one to turn the SCR's or ignitrons on and off (for current control) and one to turn an electrically operated air valve on and off (for machine control). The SCR's or ignitrons perform basically a switching function and so are connected in series with the welding transformer in much the same way any switch is connected in series with its load. Note also that they are connected in the primary rather than the secondary circuit of the transformer because the current requirements are lower in the primary.

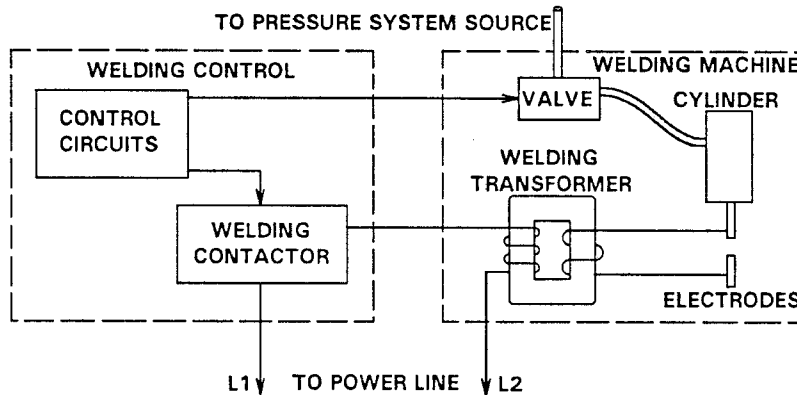

SIMPLIFIED DIAGRAM. MACHINE AND CONTROL HOOK-UP

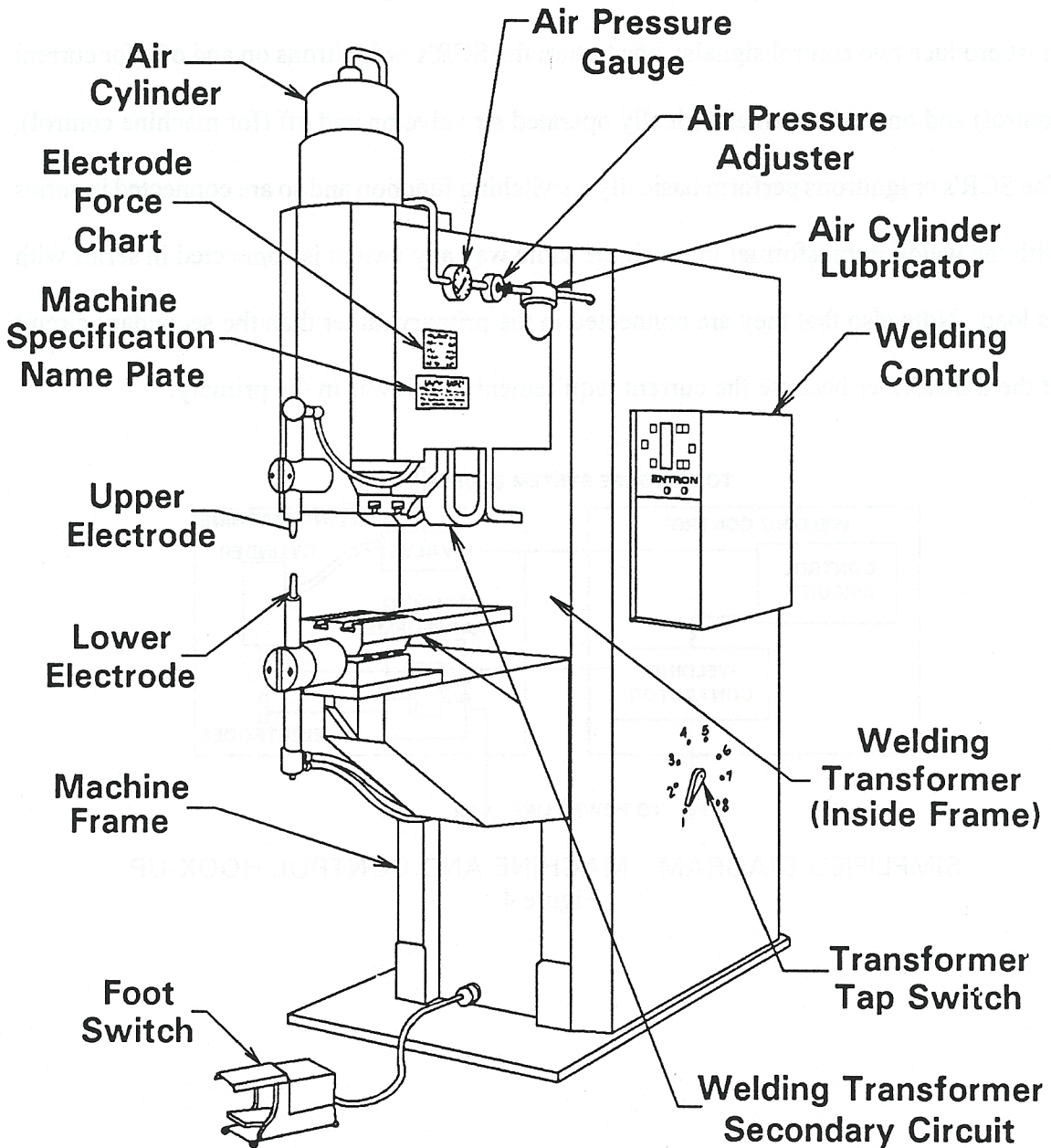

PARTS OF A TYPICAL PRESS TYPE WELDING MACHINE

Figure 5.

WELDING SEQUENCES AND DEFINITIONS

Fig. 6 explains with line drawings a typical welding sequence. The "Welding Process Times" at the top describe the welding machine operating time intervals, while the "Control Times" line at the bottom refers to the dial settings on the welding control. The following definitions may help in understanding this drawing:

Squeeze Time is the time interval between the initial application of the electrode force on the work and the first application of current. Note that this is the process definition. The control definition is the time interval between sequence initiation and beginning of weld current. Squeeze time is necessary to delay the weld current until electrode force has built up to the desired level.

Weld Time is the time during which welding current is applied to the work in making a weld. It is measured in cycles of line voltage as are all timing functions. One cycle is 1/60 of a second in a 60 Hz power system.

Hold Time is the time during which electrode force is maintained on the work after the last impulse of welding current ceases. Hold time is necessary to allow the weld nugget to solidify before releasing the welded parts.

Off Time is the time during which the electrodes are off the work. The term is only applicable where the weld cycle is repetitive (control set on "REPEAT").

Weld Current is the current in the welding circuit during the making of a weld. The amount of weld current is controlled by two things: first, the setting of the transformer tap switch determines the maximum amount of weld current available; second, the % current control

determines the % of the available current to be used for making the weld. Low % current settings are not normally recommended. Adjust the tap switch so that proper welding current can be obtained with the % current set between 70 and 90%. The only time the % current should be set below 70% is when the tap switch is on its lowest setting and 70% current is still too high.

Electrode Force is the result of air pressure applied to the air piston connected directly to the head. The actual amount of electrode force depends on the effective air pressure, weight of head, and piston diameter. Most welders have electrode force charts on the side of the machine, tabulating air pressure vs. electrode force. If there is no chart available for the machine, use the following formula:

$$\text{Electrode Force} = .78 \times D^2 \times P \text{ or } \pi \times D^2/4 \times P$$

D is the Piston Diameter in inches

P is the air pressure in pounds per square inch

Electrode Force is in pounds.

This does not allow for dead weights and friction. It may be necessary, when changing electrode force from one value to another greatly different value, to re-adjust the speed control valves. Too slow an approach wastes time and may require a much longer squeeze time. Too fast an approach impacts the electrodes and shortens their life, and may also damage the electrode holders or head. When projection welding, high impact will damage the projection before welding and result in poor projection welds even when all other settings are correct.

The Solenoid Valve is an electrically operated air valve in the compressed air line connected to the air cylinder on the welding machine. When the welding control applies voltage to this valve it opens, allowing compressed air to enter the air cylinder to develop the electrode force.

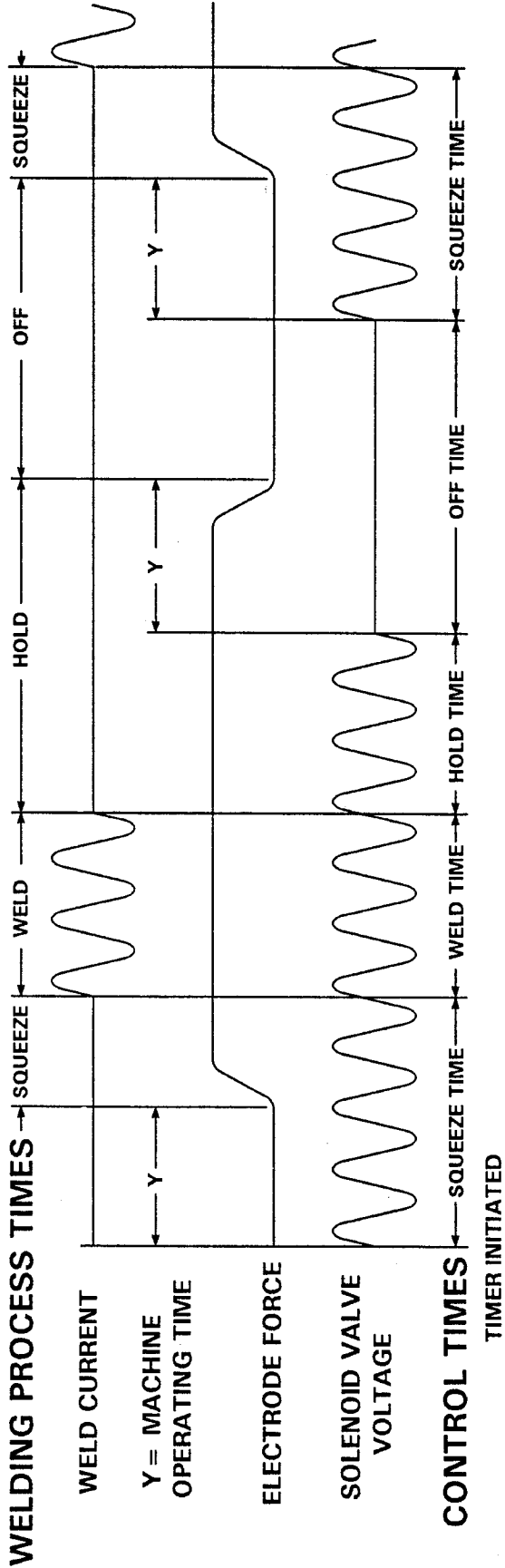

TYPICAL RESISTANCE WELDING SEQUENCE

Figure 6.

SETTING UP THE WELDING MACHINE

Table 1 can usually provide the best schedule to follow. If for some reason this schedule cannot be followed, contact your welding machine manufacturer or refer to RWMA or AWS standards for resistance welding.

Column 1 specifies the thickness to be welded. Note that this value is the thinnest of two or more sheets to be welded together. This also means that if no marking is allowed, the flat electrode must be against the thicker material. The controlled tip or electrode must be against the thinner material.

Column 2 gives the maximum size of the contact face (small "d"). Notice that the angle beyond the contact face is small (30). A small angle here will give longer electrode life, (lower rate of spreading out into too much contact area, called "mushrooming"). This dimension, (d) is very important. If it gets too large, weak welds will be made unless the weld current is turned higher and higher accordingly. Should this face, (d), be too small, electrode force and current would have to be lowered, resulting in a too-small spot. The diameter can be easily measured by measuring the diameter of the marking on the part.

Column 3 is the minimum recommended size of the electrode to carry the welding current without undue wear or rapid change of electrode contact area.

Column 4 is used where best appearance is desired. This shape of electrode must be turned on a lathe. Electrode life can be extended by the use of proper tip dressing tools.

Column 5 indicates the proper tapered holder to use to insure that the electrode force does not bury the electrode into the holder.

Column 6 specifies actual electrode force. Here the air gauge reading must be translated into electrode force. Refer to "electrode force" definition in the preceding section.

Column 7 is the weld time. This is the length of time weld current flows and can be set exactly to these values on the weld time thumbwheel.

Column 8 "hold time", must not be set shorter than these values. To do so may result in cracked or damaged welds and bad surface discoloration. Longer hold times will do no harm except to take a little longer for the over-all weld sequence.

Column 9, welding current, is the last setting to make and check out. This setting, assuming all preceding adjustments are correct, will determine the size of the spot. Therefore, it is not necessary to know the actual current in amperes because you will arrive at or near these tabulated values if the spot is the correct size or strength. (See columns 10 and 11) Check electrode contact area from time to time and make the necessary changes in % current as the electrodes wear. Re-dress electrodes as required.

Column 10 specifies the minimum shear strength of a single spot weld using test strips at least as wide as specified in column 13 (L).

Column 11 is the diameter of the fused zone. This can be checked two ways. One; peel the test strip and measure the nugget size. Two; place two test strips in "V" formation and spot weld at the bottom. Then twist the single spot in shear and measure the diameter of the fused zone.

Column 12 sets up the minimum spot spacing. This means that if a spot is placed any closer, there will be undue shunting of current into previously made spots. This in turn will result in smaller spot sizes beyond safe limits for the subsequent spots to be made. This is one of the reasons test strips should be made at the same spacing as would be made on the assembly.

Column 13 specifies the minimum overlap of the parts for best quality welds. This must be followed for test welds, especially for shear test.

OPTIMUM CONDITIONS
SCHEDULES FOR SPOT WELDING LOW CARBON STEEL-SAE 1010

1	2 Electrode Diameters and Shape*		3	4	5	6	7	8	9	10	11	12	13
	Thickness of Thinnest Outside Piece (Inches)	Flat Face											
0.010	0.125		1/2	2	Horse Taper No. 1	160	4	5	4,000	130	0.113	1/4	3/8
0.021	0.187		1/2	2	Horse Taper No. 1	244	6	8	6,500	300	0.139	3/8	7/16
0.031	0.187		1/2	2	Horse Taper No. 1	326	8	10	8,000	530	0.161	1/2	7/16
0.040	0.250		5/8	3	Horse Taper No. 2	412	10	12	8,800	812	0.181	3/4	1/2
0.050	0.250		5/8	3	Horse Taper No. 2	554	14	16	9,900	1,195	0.210	7/8	9/16
0.062	0.250		5/8	3	Horse Taper No. 2	670	18	20	10,600	1,717	0.231	1	5/8
0.078	0.312		5/8	3	Horse Taper No. 2	903	25	30	11,800	2,365	0.268	1 1/8	11/16
0.084	0.312		5/8	4	Horse Taper No. 3	1,160	34	35	13,000	3,054	0.304	1 1/4	3/4
0.109	0.375		7/8	4	Horse Taper No. 3	1,440	45	48	14,200	3,672	0.338	1 5/16	13/16
0.125	0.375		7/8	4	Horse Taper No. 3	1,760	60	65	15,600	4,300	0.375	1 1/2	7/8
0.156	0.500		7/8	6	Male or Female Threaded	2,500	93	90	18,000	6,500	0.446	1 3/4	1
0.187	0.625		1	6	Male or Female Threaded	3,340	130	55	20,500	9,000	0.516	2	1 1/4
0.250	0.750		1 1/4	6	Male or Female Threaded	5,560	230	60	26,000	18,000	.660	4	1 1/2

* Electrode Material-Class 2 Alloy

RULES FOR MAKING GOOD WELDS

1. Too short squeeze time can result in metal expulsion, burned electrodes, bad welds, marked work, and damaged ignitron tubes or SCR's.
2. Too long weld time will shorten the life of the electrodes, cause excessive indentation and cause internal cracks which can result in weld failures.
3. You cannot judge weld quality by looking at the finished weld. If non-destructive testing is used, test strips of the same material and combination must be used.
4. Too short weld time will result in low weld strength, assuming all other factors are normal.
5. Too short hold time can result in surface expulsion, electrodes sticking, internal cracks in weld nugget and sometimes even cracks in parent metal. Follow the tables for minimum time.
6. Weld pressure too low can result in expulsion of metal, electrode damage (sticking), short electrode life, internal cracks in weld nugget and sometimes excessive indentation.
7. Weld pressure too high can result in low or variable weld strength, excessive weld current requirements, mushrooming of electrodes, and excessive indentation.
8. With all other settings correct, adjust weld current to meet weld quality standards.
9. Electrode contact face too small will result in too small a spot, excessive electrode mushrooming, and excessive indentation. Too large an electrode contact area will result in too large a weld (assuming current is set accordingly) and internal cracks.
10. Electrodes misaligned or miss-matched will result in expulsion and displaced weld nugget and accelerated electrode wear.
11. Insufficient cooling will result in mushroomed and short life electrodes, cracks on the surface and excessive indentation in some cases. It is very important that the water

flow in through the water quill and back out the outside of the quill. Also, the water quill must be bottomed gently against the inside of the electrode cavity every time an electrode is replaced.

12. Dirty material - Dirt sticking on the surface will shorten electrode life and mark and burn the work surface.
13. Excessive electrode approach speed will accelerate electrode wear and damage equipment. On projection welding, it can damage the projection, resulting in poor weld quality.
14. Don't make a weld over the same spot twice to try to cover up for a bad weld. To do so effectively, the work must cool and then be hit with a much higher current. If you cannot get a weld with one hit, either the set-up of the machine is incorrect or you are not using a machine of sufficient size to make the weld.