

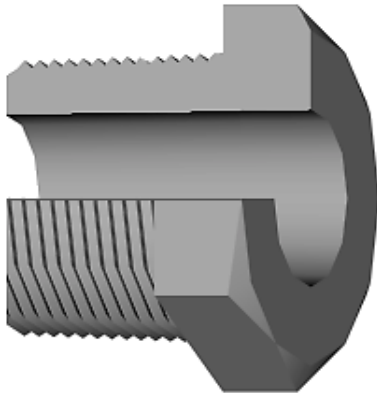

ADAPTERS,  
MALE PIPE THREAD TO FEMALE TAPER

**FEATURES AND SPECIFICATIONS**



**Features and Benefits**

- Adapters convert holders with pipe thread into changeable 4, 5, and 6 RWMA tapers

**Use With**

- Series 100, 200, 300, & 600 holders

**Mechanical**

- RWMA 4, 5, & 6 tapers

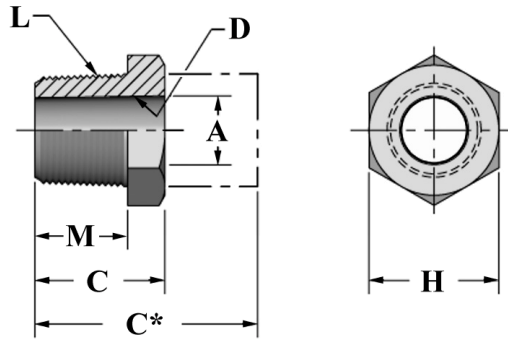

**ORDERING INFORMATION AND DIMENSIONS**

L MALE THREAD SIZE	FEMALE TAPER		ADAPTER PART NO.	DIMENSIONS (in inches)		
	D SIZE	A MAJOR DIA.		M LENGTH UNDER HEAD	H HEX OVER FLATS	C OVERALL LENGTH
1/2-14 pipe	4RW	0.463	18-746-07	5/8	1	7/8
	5RW	0.613	18-747-07			
	5RW	0.414	18-7465-07	9/16	7/8	
5/8-14 pipe	4RW	0.463	18-748-06		1	3/4
	5RW	0.613	18-749-06			
3/4-14 pipe	4RW	0.463	18-756-09	7/8	1-1/4	1-1/8
	5RW	0.613	18-757-09			
	6RW	0.731	18-7576-09			

\* Adapters of longer lengths available in 1/8" increments upon request