

ADAPTERS,  
MALE THREAD TO FEMALE TAPER



**FEATURES AND SPECIFICATIONS**

**Features and Benefits**

- Adapters convert holders into changeable 4, 5, and 6 RWMA tapers

**Use With**

- Use series 100, 200, 300, and 600 holders

**Mechanical**

- RWMA 4, 5, 6 tapers

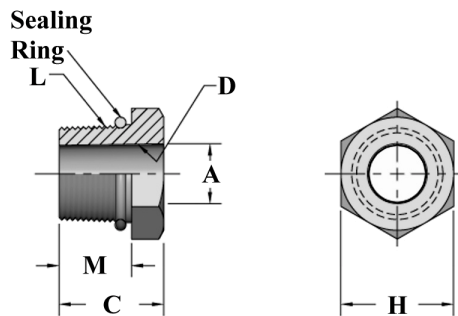
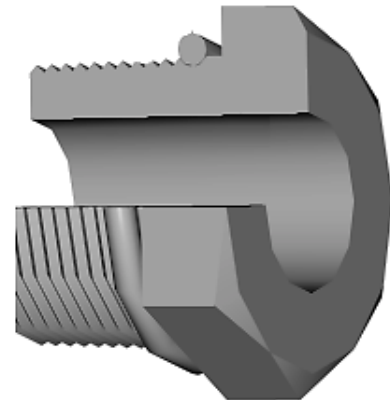

**ORDERING INFORMATION AND DIMENSIONS**

L MALE THREAD SIZE	FEMALE TAPER		ADAPTER PART NO.	DIMENSIONS (in inches)			SEALING RING PART NO.
	DIMENSIONS (in inches)			M LENGTH UNDER HEAD	H DIA. OR HEX	C OVERALL LENGTH	
	D SIZE	A MAJOR DIA.					
5/8-18	4RW	0.463	18-750	9/16	7/8 HEX	13/16	18-10060-11
	5RW	0.613	18-751		1 HEX	1-11/16	18-10060-11
3/4-10			18-755*		1 DIA.	1-9/16	18-10060-12
7/8-14	4RW	0.463	18-770	5/8	1 HEX	13/16	18-76460
	5RW	0.613	18-771				18-76460
1-14	5/8-18 THD	--	18-7743	9/16	1-1/4 HEX	1	18-10060-17
	4RW	0.463	18-785			13/16	18-10060-17
	5RW	0.613	18-786			18-10060-17	
	6RW	0.731	18-7863	3/4	1-3/4	18-10060-17	
	7RW	0.844	18-787		2-1/8	18-10060-17	
	5RW	0.613	18-7875	9/16	1-1/4 DIA.	11/16	18-10060-17
	6RW	0.731	18-7876	5/8		7/8	18-10060-17

\* This part has 3/4" wrench flats