



FEATURES AND SPECIFICATIONS

Features and Benefits

- Custom made assemblies for making two or more spot welds at one time using hydraulic equalizing pressure

Use With

- Nu-twist electrodes or adapters for RWMA electrodes

Mechanical

- Spacing and number of units to be specified by customer

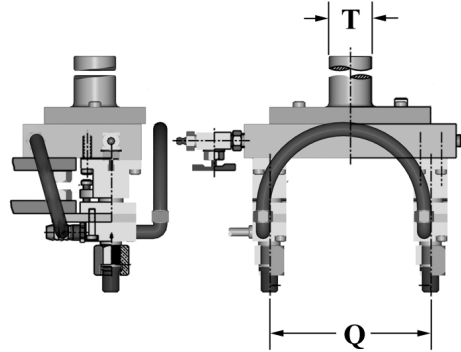
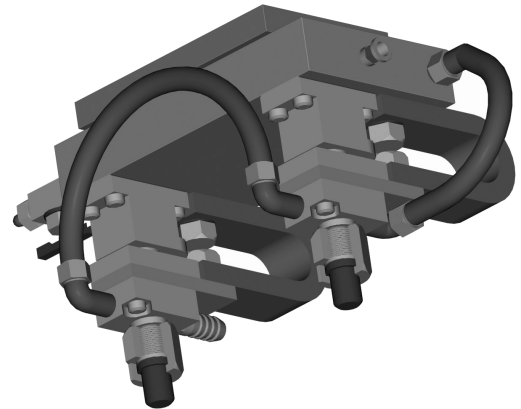

ORDERING INFORMATION AND DIMENSIONS

UNIT SIZE	MOUNTING "T" DIA.	PRODUCT NO.	SPACING "Q" (SPECIFY ON ORDER)
#1	NONE	18-846	1-1/32" TO 5"
	1"	18-84601-01	
	1-1/4"	18-84601-02	
	1-1/2"	18-84601-03	
#2	NONE	18-847	1-3/4" TO 6"
	1"	18-84701-01	
	1-1/4"	18-84701-02	
	1-1/2"	18-84701-03	

NOTE:

1. MULTIPLE HEADS 2-8 CAN ALSO BE SUPPORTED.

2. A FIELD ADJUSTABLE UNIT FOR SPACING "Q" IS AVAILABLE WITH A SPACE RANGE OF 1-1/32" TO 3-1/2" PRODUCT # 18-836 W/O "T" PLATE OR WITH "T" PLATE PRODUCT #18-83614.