



NUT WELDING ELECTRODES, THREADED
CHAMELEON MAX-LIFE™

FEATURES AND SPECIFICATIONS



Features and Benefits

- Long life nut welding electrode system with retractable locators
- Replaceable insulated stainless steel locator pins
- Replaceable long life ELKONITE® face
- For threaded holders
- For 4mm-9mm nuts
- Air port for flash removal

Use With

- Threaded adapters in platen mounted holder in special fixtures

Mechanical

- Accepts external cooling chambers*



*External Electrode Cooling Chamber

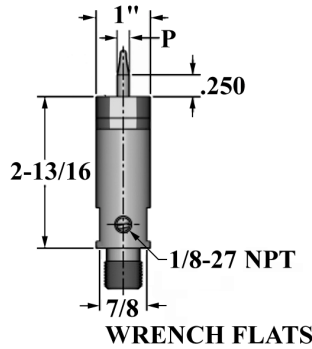

ELECTRODES
STUD/NUT

ORDERING INFORMATION AND DIMENSIONS

THREAD SIZE	SCREW THREAD SIZE	PIN DIA. P	PART NO.	CMW®3 BASE	SPRING	CERAMIC COATED STAINLESS STEEL PIN	ELKONITE® 10W3 FACED CAP	USE WITH COOLING CHAMBER*
5/8-18 UNF THREAD	4 mm	0.187	16-37825-M4	16-37825	16-950065-01	16-950064-M4	16-37825-CM4	18-1342
	5 mm	0.226	16-37825-M5	16-37825	16-950065-01	16-950064-M5	16-37825-CM5	
	6 mm	0.266	16-37825-M6	16-37825	16-950065-01	16-950064-M6	16-37825-CM6	
	7 mm	0.305	16-37825-M7	16-37825	16-950065-01	16-950064-M7	16-37825-CM7	
	8 mm	0.344	16-37825-M8	16-37825	16-950065-01	16-950064-M8	16-37825-CM8	
	9 mm	0.384	16-37825-M9	16-37825	16-950065-01	16-950064-M9	16-37825-CM9	