

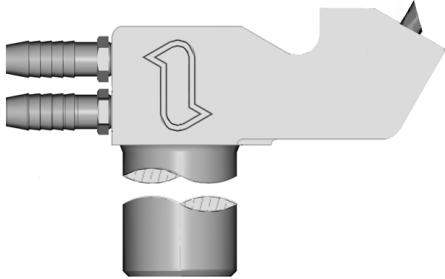

**HOLDERS (400 SERIES)
(CONVENTIONAL SHANK 30°)**

FEATURES AND SPECIFICATIONS



Features and Benefits

- Head at 30° angle for hard to reach areas
- Non-ejector offset holders.
- Designed to reach into box type applications
- For light duty applications

Use With

- All tapered electrodes

Mechanical

- Fits all RWMA 4 & 5 tapered electrodes

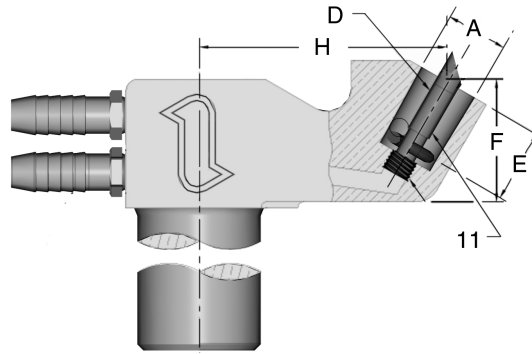

ORDERING INFORMATION AND DIMENSIONS

D	A	B	PART NO.	E	F	H	11
RWMA TAPER	MAJOR TAPER DIA.	SHANK DIA.	HOLDER ASSEMBLY	ENGAGEMENT WITH STD. ELECTRODE	HEAD HEIGHT	OFFSET	SLIDING TUBE (REPLACEMENT PART)
4	.463	7/8	18-442	1/2	1	2	18-40043-1
		1	18-443				
		1-1/4	18-444				
5	.625	1	18-448	3/4	1-1/4	2	18-40043-2
		1-1/4	18-449				
		-	-				
4	.463	7/8	18-462	1/2	1	4	18-40043-1
		1	18-463				
		1-1/4	18-464				
5	.625	1	18-468	3/4	1-1/4	4	18-40043-2
		1-1/4	18-469				
		-	-				

HOLDERS