

HOLDERS WITH THREADED ADAPTERS (EJECTOR)  
(500 SERIES PREMIUM) WATER COOLED OFFSET 30°



**FEATURES AND SPECIFICATIONS**

**Features and Benefits**

- Heavy duty offset holder
- For demanding applications
- 30° for hard to reach areas

**Use With**

- All standard electrodes

**Mechanical**

- RWMA 5 & 7 tapers

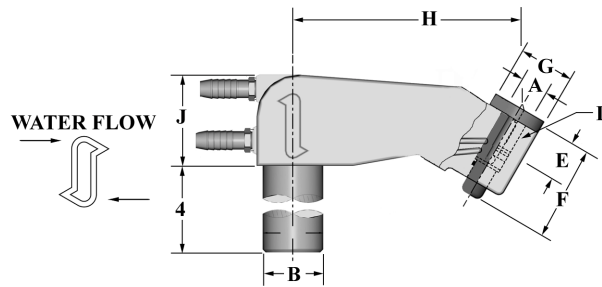
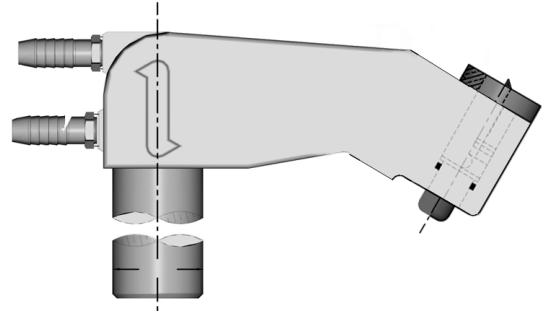

**ORDERING INFORMATION AND DIMENSIONS**

D	A	B	PART NO.	J	E	F	G	H	11	PART NO.
RWMA TAPER	MAJOR TAPER DIA.*	SHANK DIA.*	HOLDER ASSEMBLY	HEAD THICKNESS*	STANDARD TAPER ENGAGEMENT*	HEAD HEIGHT*	HEAD DIA.*	C.L. SHANK OFFSET*	SLIDING TUBE (REPLACEMENT PART)	THREADED ADAPTER
5	0.625	1-1/4	18-5635	1-7/8	3/4	1-13/16	1-1/4	4	18-40043-3	18-7875
		1-1/2	18-5645							
6	0.750	1-1/4	18-5636		7/8	1-15/16	1-1/4	4	18-40043-3	18-7876
		1-1/2	18-5646							

\*DIMENSIONS (in inches)

HOLDERS