



**FEATURES AND SPECIFICATIONS**

**Features and Benefits**

- Holders for use on multi-spot air or hydraulic cylinders. Ready to attach welding cable and water lines.

**Use With**

- Appropriate electrode

**Mechanical**

- Used with 3/4" diameter air and hydraulic straight rod pistons

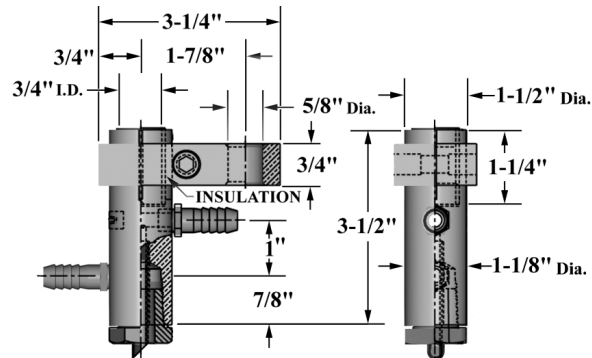
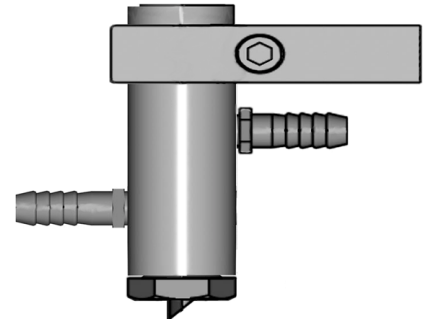

**ORDERING INFORMATION AND DIMENSIONS**

ATTACHMENT DIA.	ASSEMBLY PART NO.	MAJOR TAPER
1/2-14 NPT	18-1201	--
5RW MALE CAP	18-1202	0.4145
4RW	18-1203	0.463
5RW	18-1204	0.625