

EXAMPLE OF PART CODING:	
TR =	TIPALOY ROUND FACE TIP
2 =	CLASS 2 COPPER
5 =	#5 RW TAPER
24 =	OVERALL LENGTH IN 1/16"
14 =	WELD FACE DIAMETER IN 1/16"
16 =	WATER HOLE DEPTH IN 1/16" IF DIFFERENT THAN STANDARD (7/8")
CT =	COPPER TUNGSTEN FACING

ROUND FACE TIPS

New Part No.	Old Part No.	Overall Length	Weld Face	Face to Water Dia.	Length of Face Hole
		A	B	C	F
4 RW Taper (#1 MT)					
TR-24-24-14	SP-221-1	1-1/2	7/8	5/8	7/8
TR-24-20-16-13	SP-222	1-1/4	1	7/16	5/8
TR-24-20-12-16	SPB-680-1	1-1/4	3/4	1/4	5/8
TR-24-20-20-16	SPB-682-1	1-1/4	1-1/4	1/4	5/8
TR-24-32-14-20	SP-279	2	7/8	3/4	1-3/8
5 RW Taper (#2 MT)					
TR-25-24-14-14	SP-221-2	1-1/2	7/8	5/8	5/8
TR-25-24-16-18	SP-223	1-1/2	1	3/8	1
TR-25-30-14-14	SP-250	1-7/8	7/8	1	1
TR-25-24-14-18	SP-292-2	1-1/2	7/8	3/8	5/8
TR-25-24-12-18	SPB-681-2	1-1/2	3/4	3/8	5/8
TR-25-24-20-18	SPB-682-2	1-1/2	1-1/4	3/8	5/8
TR-25-46-12-14	SP-275	2-7/8	3/4	2	2
TR-25-46-16-14	SP-276	2-7/8	1	2	2
TR-25-32-16-20	SP-280	2	1	3/4	1-1/8
TR-25-32-24-16	SPB-510-2	2	1-1/2	1	1-1/8

* Additional diameters and lengths available from stock.

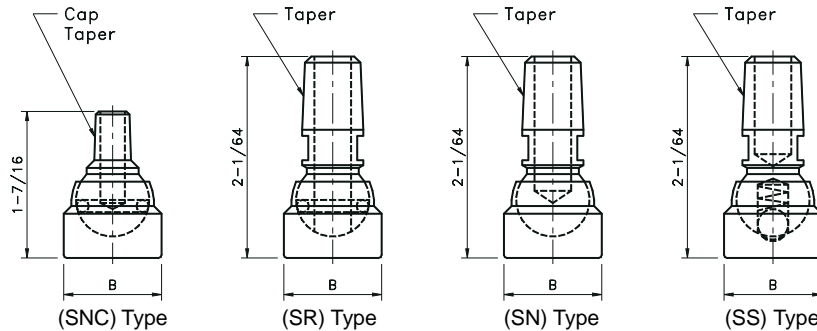

SWIVEL TIPS

5 RW Male Cap Taper Part No.	Spring Ball Type Part No.	Blind Hole Type Part No.	O Ring Type Part No.	Weld Face Diameter B
4 RW Taper (#1 MT)				
-	SS-147	SN-147	SR-147	7/8
-	SS-148	SN-148	SR-148	1
-	SS-1410	SN-1410	SR-1410	1-1/4
-	SS-1412	SN-1412	SR-1412	1-1/2
5 RW Taper (#2 MT)				
SNC-157	SS-157	SN-157	SR-157	7/8
SNC-158	SS-158	SN-158	SR-158	1
SNC-1510	SS-1510	SN-1510	SR-1510	1-1/4
-	SS-1512	SN-1512	SR-1512	1-1/2

EXAMPLE OF PART CODING:	
SNC =	SWIVEL - MALE CAP TAPER
SS =	SWIVEL - SPRING AND BALL TYPE
SNC =	SWIVEL - BLIND HOLE TYPE
SR =	SWIVEL - "O" RING TYPE
1 =	CLASS 2 COPPER
4 =	#4 RW TAPER
7 =	WELD FACE DIAMETER IN 1/8"

SWIVEL & ROUND FACE TIPS