

## AIR PRESSURE NUT ELECTRODES

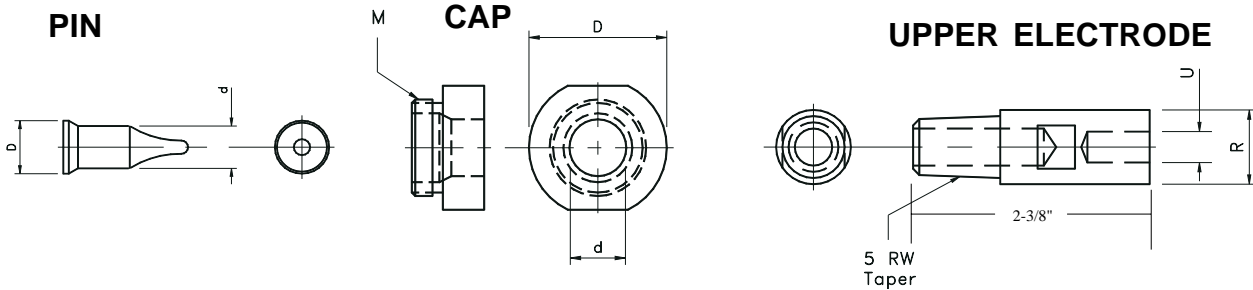

PIN			CAP				UPPER ELECTRODE		NUT	
NUMBER	d	D	NUMBER	D	d	M	ELECTRODE	SIZE	R	U
TDP-M04	5	12	TCN-M04	25	5	18	TNFD-16-M5-16-3	M 4-6	16MM	5MM
TDP-M05	6	12	TCN-M05	25	6	18	TNFD-16-M5-16-3	M 4-6	16MM	5MM
TDP-M06	7	12	TCN-M06	25	7	18	TNFD-20-M6-16-3	M 6-7	20MM	6MM
TDP-M07	8	12	TCN-M07	25	8	18	TNFD-20-M6-16-3	M 6-7	20MM	6MM
TDP-M08	9	12	TCN-M08	25	9	18	TNFD-20-M8-16-3	M 8-9	20MM	7.5MM
TDP-M09	10	12	TCN-M09	25	10	18	TNFD-20-M8-16-3	M 8-9	20MM	7.5MM
TDP-M10	11	16	TCN-M10	32	11	22	TNFD-20-M10-16-3	M 10-11	20MM	10MM
TDP-M11	12	16	TCN-M11	32	12	22	TNFD-20-M10-16-3	M 10-11	20MM	10MM
TDP-M12	13	16	TCN-M12	32	13	22	TNFD-20-M12-16-3	M 12-13	20MM	12MM
TDP-M13	14	16	TCN-M13	32	14	22	TNFD-20-M12-16-3	M 12-13	20MM	12MM

NOTE: For solid copper tungsten heads please add a "-CT" to the end of the part number.

NOTE: For copper tungsten faced electrodes please add a "-CT" to the end of the part number.

BODY NUMBER	D	TAPER / THREAD	CAP THREAD
TDH-25-A	25	MT #1	18MM
TDH-25-B	25	1/10	18MM
TDH-25-C	25	MT #2	18MM
TDH-25-D	25	1/10	18MM
TDH-25-E	25	1/5	18MM
TDH-30-A	32	MT #2	22MM
TDH-30-B	32	1/10	22MM
TDT-25-C	25	5/8-11	18MM
TDT-30-C	32	5/8-11	22MM
TDT-25-C-CL	25	5/8-11	5/8-18
TDT-30-A-CL	32	5/8-11	7/8-14

Specials available upon request.

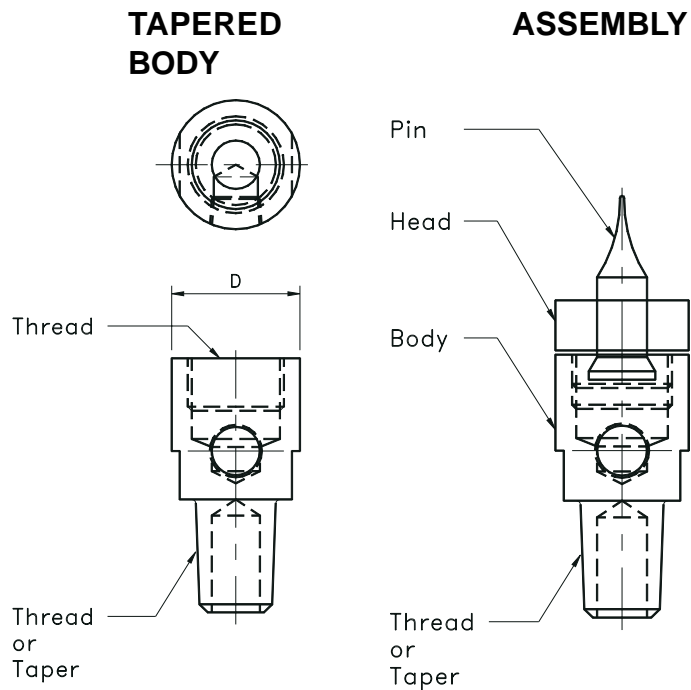

AIR PRESSURE NUT ELECTRODES